

Erdung nach örtlichen Vorschriften
 Mise à la terre conformément au réseau local
 Messa a terra in conformità alla rete locale
 Aarding in overeenstemming met het plaatselijk net
 Earthing in accordance with local regulation

Einspeisung
 Alimentation électrique
 Alimentazione elettrica
 Elektrische voeding
 Power supply

Kessel / Chaudière / Caldaia / Ketel / Boiler

OPTIONEN / OPTIONS / OPZIONI / OPTIES / OPTIONS

Prinzipdarstellung
 Schéma de principe
 Schema generale
 Principeschema
 Basic circuit diagram

F1
 Sicherheitsbegrenzer
 Th./pr. de sécurité
 Termostato di sicurezza
 Beveiliging thermostaat
 Safety limiter

S6
 Begrenzer
 Limiteur
 Limitatore
 Begrenzingsthermostaat
 Limiter

H6
 Störung
 Panne
 Inconveniente
 Storing
 Trouble

P7
 Betriebsstundenzähler
 Compteur horaire
 Contaore
 Uurteller
 Running hours meter

S7
 2 Stufig oder PID
 2 allures ou PID
 2 stadi o PID
 2 trap of PID
 2 stages or PID

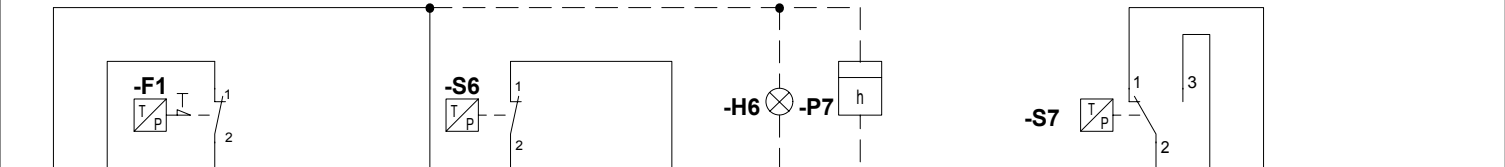
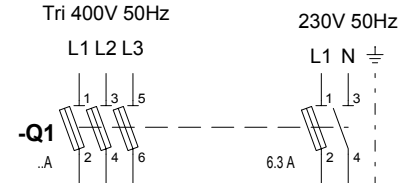

Brenner
 Brûleur
 Bruciatore
 Brander
 Burner

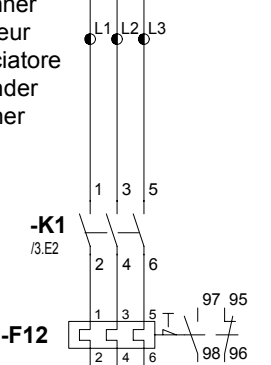

Der Schutz der Anlage muss den geltenden Normen entsprechen.
 La protection de l'installation doit être conforme aux normes en vigueur.
 La protezione dell'installazione deve essere in conformità alle norme in vigore.
 Bescherming van de installatie moet in overeenstemming volgens de wettelijk geldende normen.
 Protection of the installation must comply with the actual norms.

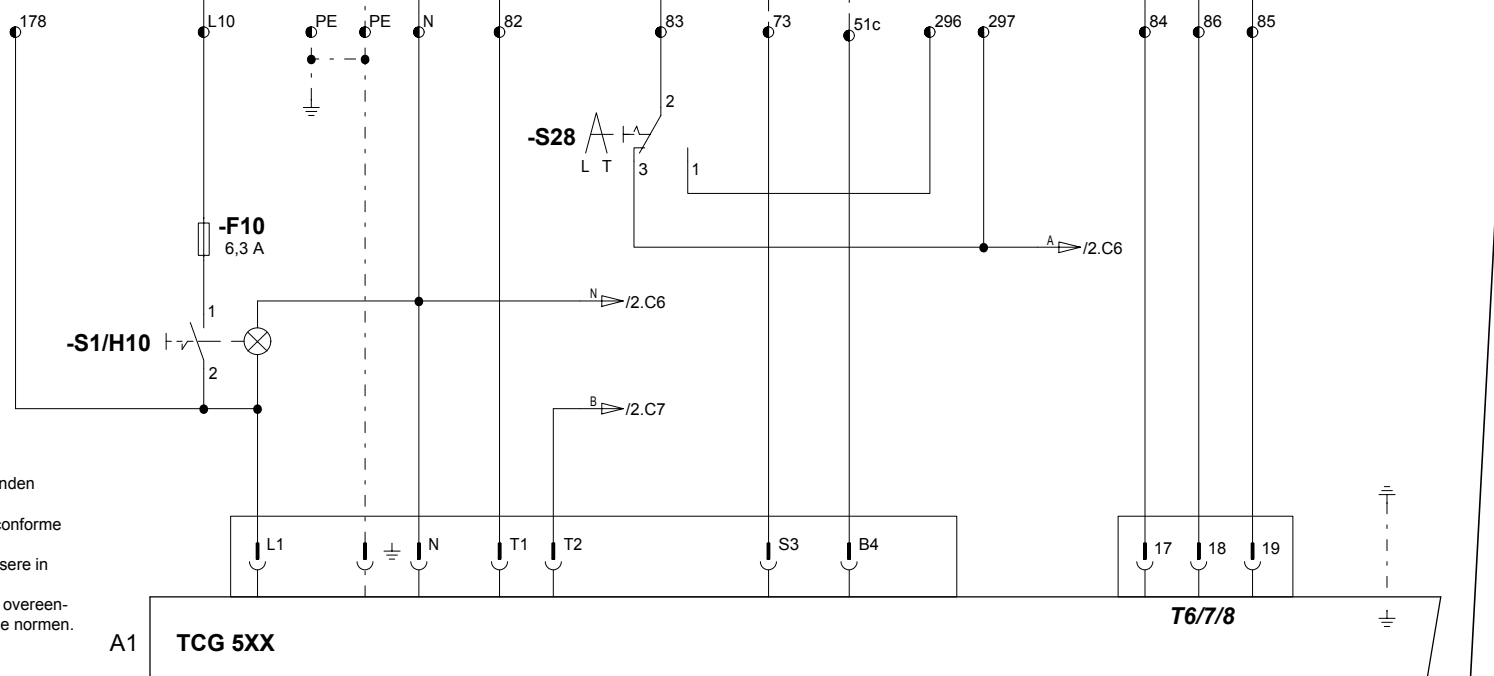

A
B
C
D
E
F

Brenner
Brûleur
Bruciatore
Brander
Burner

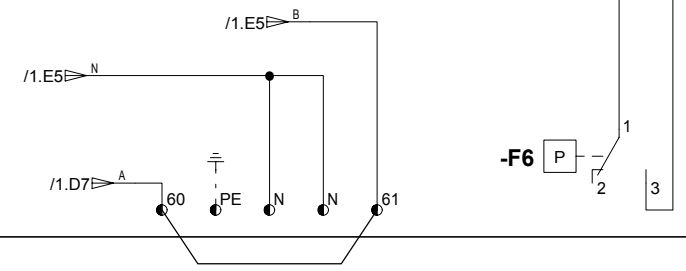
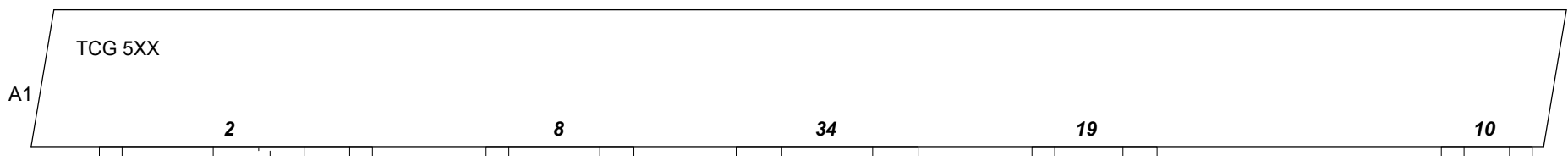

Siehe Seite 4/5
Voir page 4/5
Ved. pagina 4/5
Zie . bladzijde 4/5
See page 4/5

Siehe Seite 4/5
Voir page 4/5
Ved. pagina 4/5
Zie . bladzijde 4/5
See page 4/5

Siehe Seite 4/5
Voir page 4/5
Ved. pagina 4/5
Zie . bladzijde 4/5
See page 4/5

Brenner
Brûleur
Bruciatore
Brander
Burner

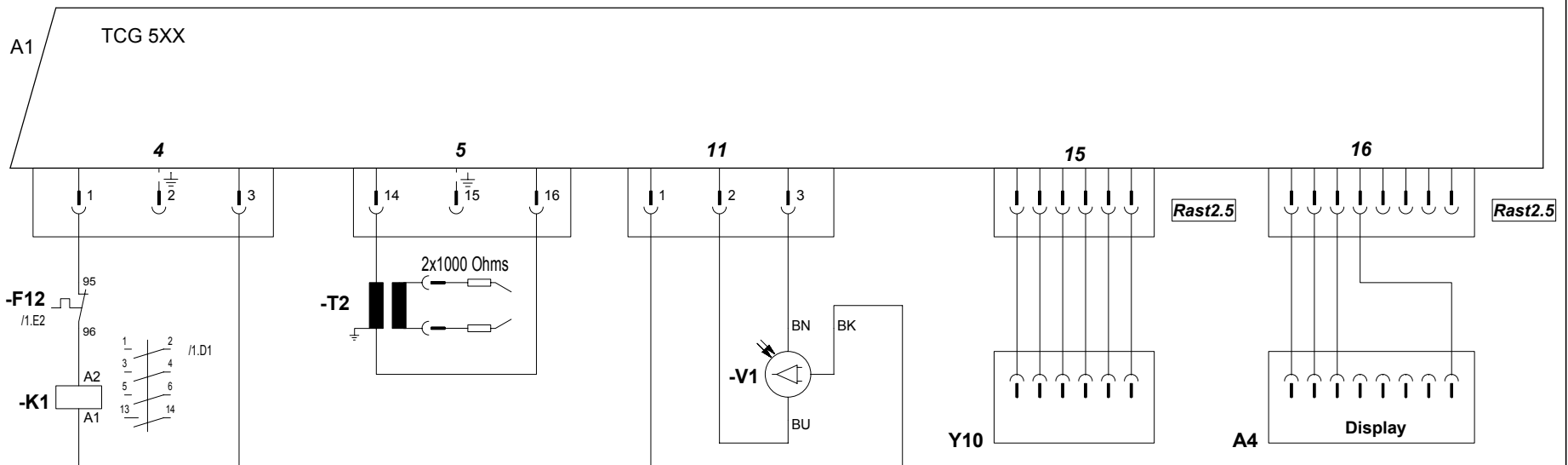

A
B
C
D
E
F



MB-VEF... S32

Brenner
Brûleur
Bruciatore
Brander
Burner

A1

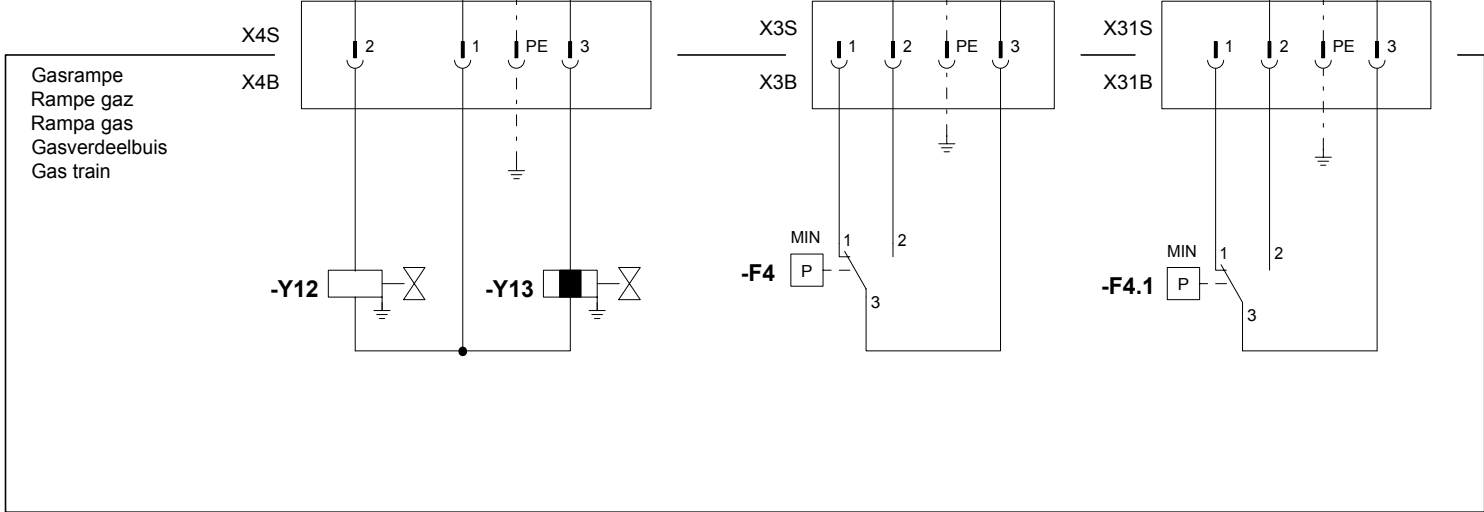
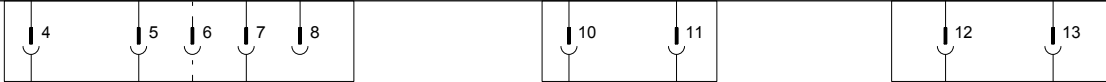

F4.1 Gasdruckwaechter min.
(TCG Dichteprüfgerät)
Manostat gaz mini
(TCG Contrôleur d'étanchéité)
Pressostato gas min.
(TCG Controllo della tenuta)
Gaspressostaat min.
(TCG Dichtheidcontroleur)
Min. gas pressure switch
(TCG Tightness controller)



VGD

Brenner
Brûleur
Bruciatore
Brander
Burner

A1

TCG 5XX

2

8

34

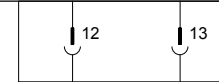
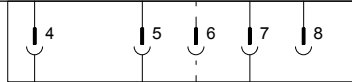

F4.1 Gasdruckwächter min.
(TCG Dichteprüfgerät)
Manostat gaz mini
(TCG Contrôleur d'étanchéité)
Pressostato gas min.
(TCG Controllo della tenuta)
Gaspressostaat min.
(TCG Dichtheidcontroleur)
Min. gas pressure switch
(TCG Tightness controller)

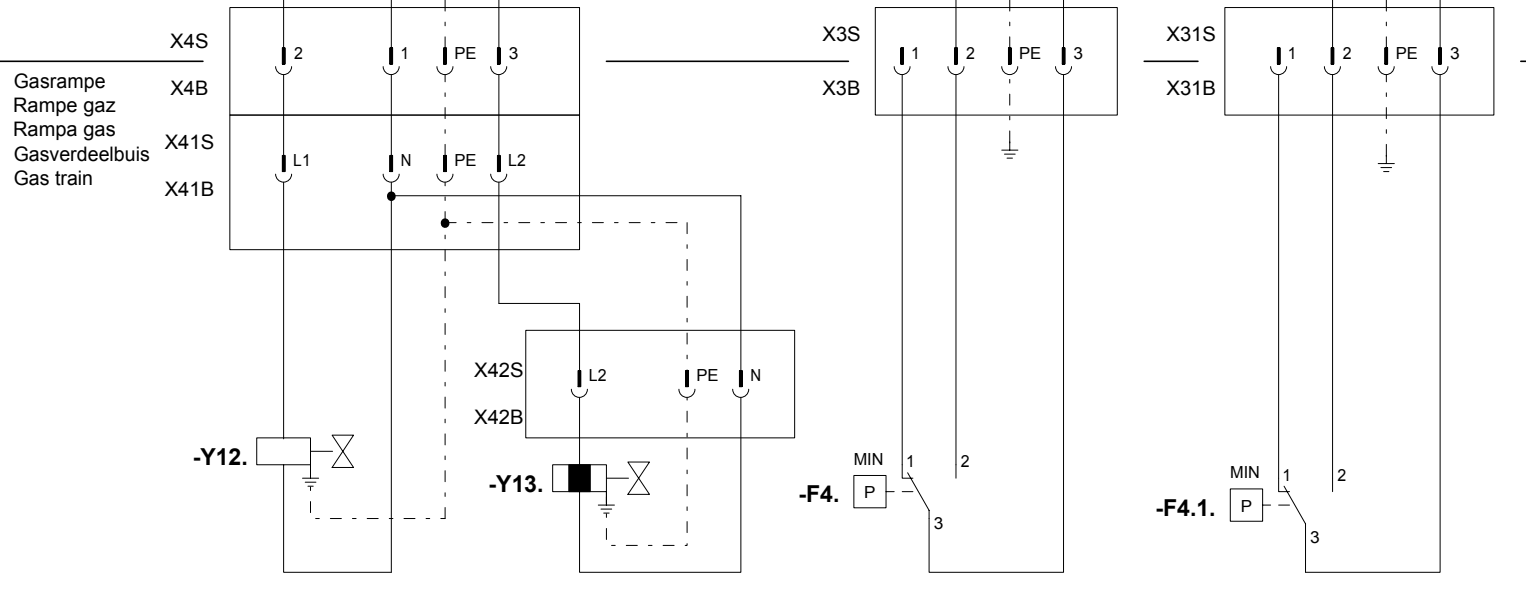

	"DE"	"FR"	"IT"	"NL"	"EN"	
A	A1	Feuerungsautomat	Coffret de contrôle	Programmatore di comando	Bedienings en veiligheidskoffer	Control and safety unit
	A4	Display	Afficheur	Visualizzatore	Uitlezing	Display
	F4	Gasdruckwaechter min.	Manostat gaz mini	Pressostato gas min.	Gaspressostaat min.	Min. gas pressure switch
	F4.1	Gasdruckwaechter min. (TCG Dichteprüfgerät)	Manostat gaz mini (TCG Contrôleur d'étanchéité)	Pressostato gas min. (TCG Controllo della tenuta)	Gaspressostaat min. (TCG Dichtheidcontroleur)	Min. gas pressure switch (TCG Tightness controller)
	F6	Luftdruckwächter	Manostat d'air	Pressostato aria	Luchtpressostaat	Air pressure switch
B	F10	Sicherung	Fusible	Fusibile	Zekering	Control fuse
	F12	Wärmeschutz M1	Protection thermique M1	Protezione termica M1	Thermische bescherming M1	Thermal protection M1
	K1	Kontaktschalter des Ventilators	Contacteur du ventilateur	Contattore del ventilatore	Contacteur van ventilator	Fan unit contactor
	M1	Brennermotor	Moteur du brûleur	Motore del bruciatore	Brandermotor	Burner motor
	S1/H10	Ein/Aus	Marche/arrêt	Acceso/spento	Aan/Uit	ON/OFF
C	S28	Inter-Fernsteuerung / Vor Ort	Inter. Télécommande/local	Interr. Telecomando/locale	Schakelaar Afstandsbediening/lokaal	Local/remote control inter.
	T2	Zündtrafo	Transformateur d'allumage	Trasformatore d'accensione	Ontstekingstransformator	Ignition transformer
	V1	Flammenwächter	Cellule	Rivelatore di fiamma	Fotocel	Cell
	Y10	Luftklappen-Stellantrieb	Servomoteur air	Servomotore aria	Servomotor lucht	Air damper motor
	Y12	Gasventil gasseitig	Vanne gaz de sécurité	Valvola sicurezza gas	Veiligheidsventiel gas	Safety gas valve
	Y13	Gasventil brennerseitig	Vanne gaz principale	Valvola principale gas	Hoofdafsluiter gas	Gas valve burner side
D	296/297	Ein/Aus ferngesteuert	Marche/arrêt par télécommande	Acceso/spento con telecomando	Aan/Uit met afstandsbesturing	ON/OFF by remote control
E						
F						

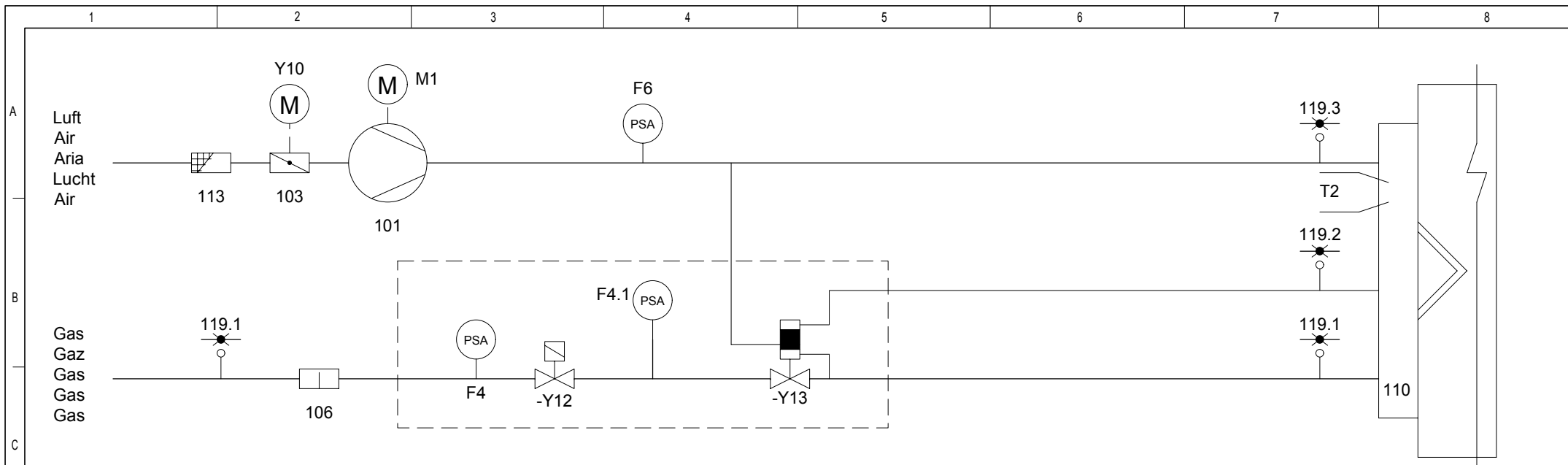

F4	Gasdruckwaechter min.	Manostat gaz mini	Pressostato gas min.	Gaspressostaat min.	Min. gas pressure switch
F4.1	Gasdruckwaechter min. (TCG Dichteprüfgerät)	Manostat gaz mini (TCG Contrôleur d'étanchéité)	Pressostato gas min. (TCG Controllo della tenuta)	Gaspressostaat min. (TCG Dichtheidcontroleur)	Min. gas pressure switch (TCG Tightness controller)
F6	Luftdruckwächter	Manostat d'air	Pressostato aria	Luchtpressostaat	Air pressure switch
M1	Brennermotor	Moteur du brûleur	Motore del bruciatore	Brandermotor	Burner motor
T2	Zündtrafo	Transformateur d'allumage	Trasformatore d'accensione	Ontstekingstransformator	Ignition transformer
Y10	Luftklappen-Stellantrieb	Servomoteur air	Servomotore aria	Servomotor lucht	Air damper motor
Y12	Gasventil gasseitig	Vanne gaz de sécurité	Valvola sicurezza gas	Veiligheidsventiel gas	Safety gas valve
Y13	Gasventil brennerseitig	Vanne gaz principale	Valvola principale gas	Hoofdafsluiter gas	Gas valve burner side
101	Ventilator	Ventilateur	Ventilatore	Ventilator	Blower
103	Luftklappe	Volet d'air	Serranda aria	Luchtklep	Air flap
103.1	Gasklappe	Volet de gaz	Serranda gas	Gasklep	Gas flap
104	Druckregler	Régulateur de pression	Regolatore della pressione	Drukregelaar	Pressure regulator
106	Filter	Filtre	Filtro	Filter	Filter
108	Handventil	Vanne manuelle	Valvola manuale	Handventiel	Manual valve
110	Gasinjektor	Injecteur gaz	Ugello gas	Gasinjector	Gas injector
113	Ansauggitter	Grille d'aspiration	Scatola dell'aria	Luchthuis	Air box protection
119.1	Messnippel Gas	Prise pression gaz	Preso pressione gas	Meetnippel Gas	Gas pressure take-off
119.2	Messnippel Feuerraum	Prise pression foyer	Preso pressione focolare	Drukmeetnippel haard	Pressure pickup furnace
119.3	Messnippel Luft	Prise pression air	Preso pressione aria	Meetnippel Lucht	Air pressure take-off