

Der Schutz der Anlage entspricht den geltenden Normen.
 Protection de l'installation conforme aux normes en vigueur.
 Protection of the installation in conformity with the actual norms.

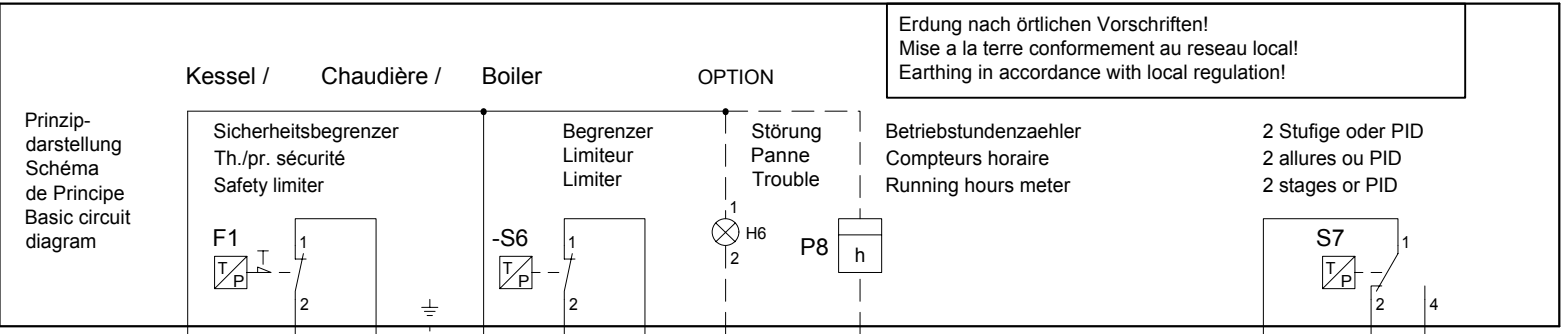

Erdung nach örtlichen Vorschriften!
 Mise a la terre conformément au reseau local!
 Earthing in accordance with local regulation!

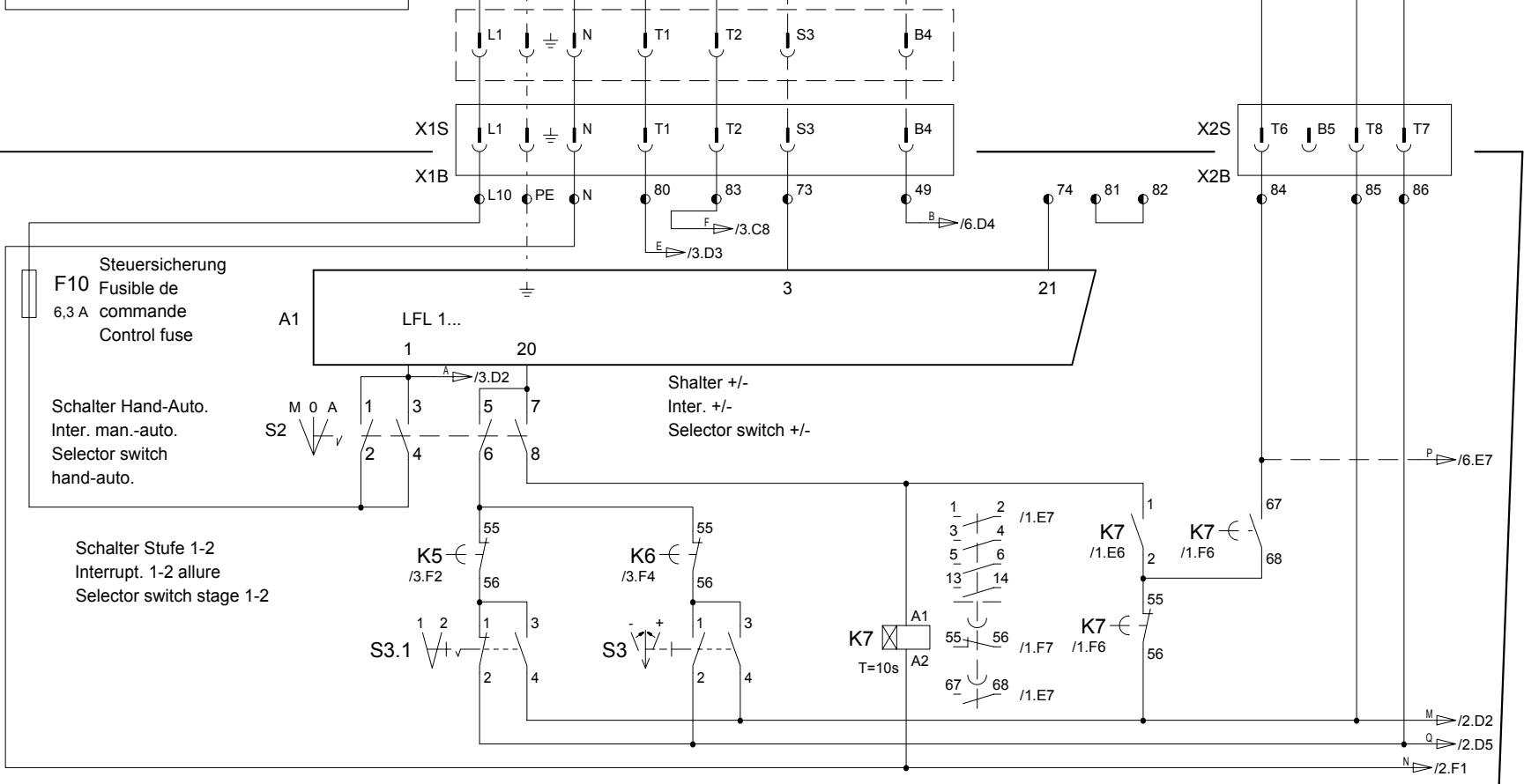

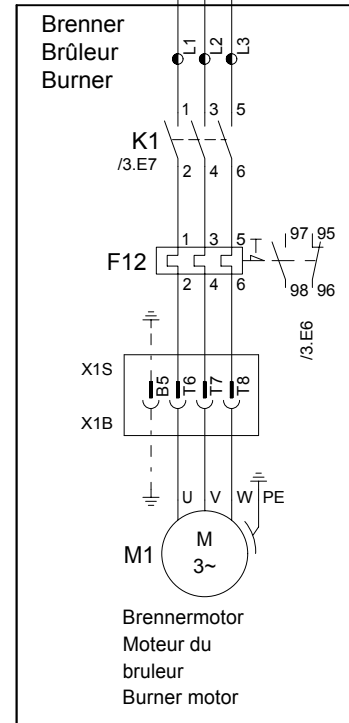
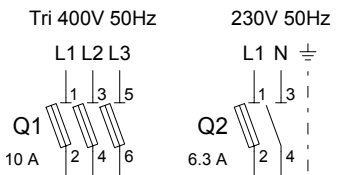
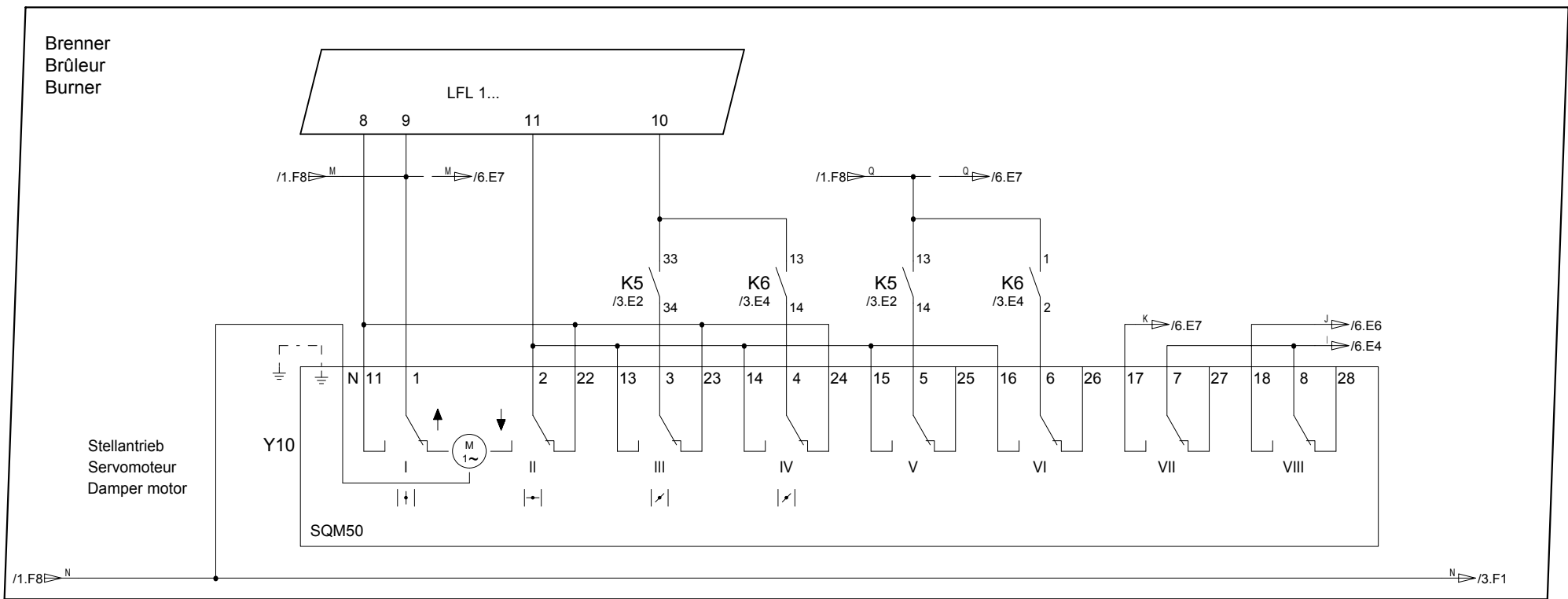

S28 Schalter brennstoffwahl
Lokal /0/ Tele

S4 Schalter brennstoffwahl
Gas /0/ Fuel

OPTION

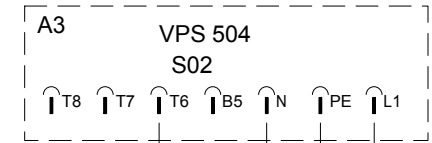

Siehe Seite 6
Voir page 6
See page 6

Siehe Seite 5
Voir page 5
See page 5

Gasstrecke / Rampe gaz / Gas valve unit

Brenner
Brûleur
Burner

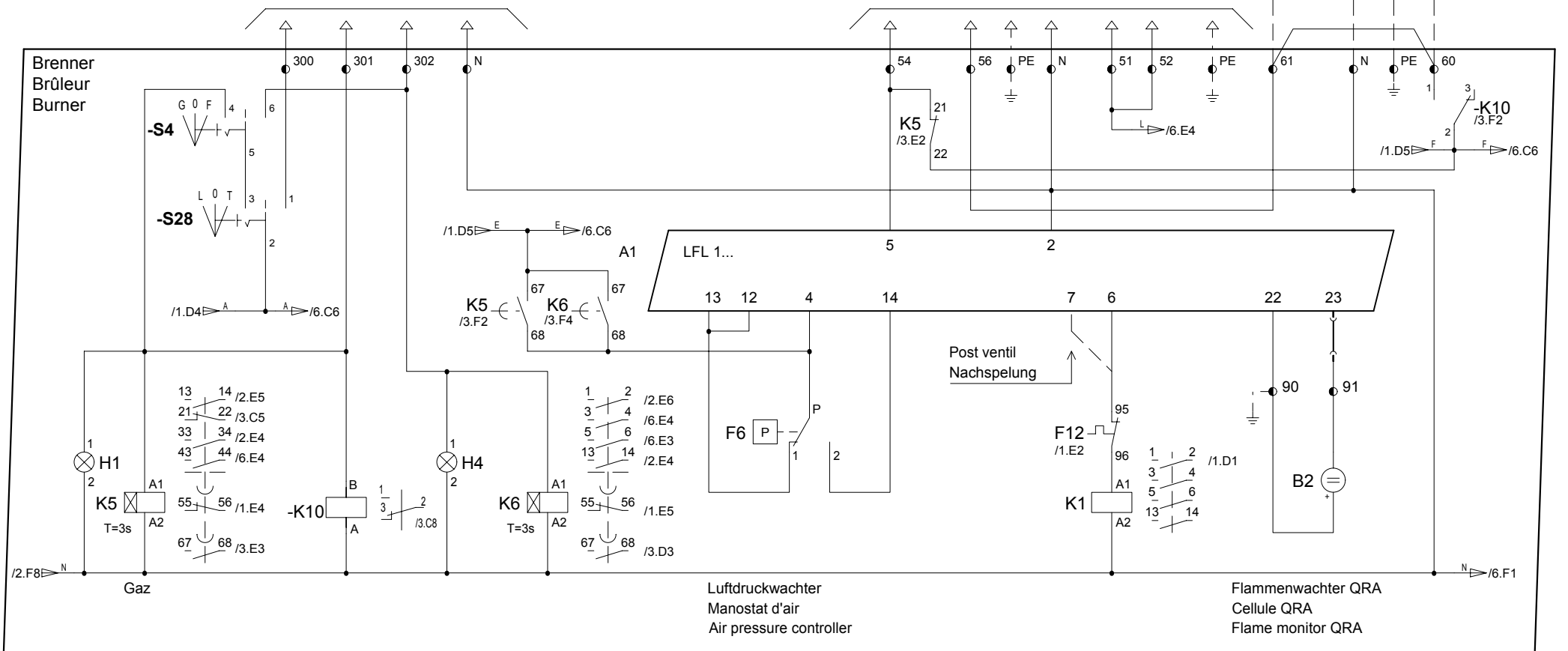

Luftdruckwacher
Manostat d'air
Air pressure controller

Flammenwacher QRA
Cellule QRA
Flame monitor QRA

A
B
C
D
E
F

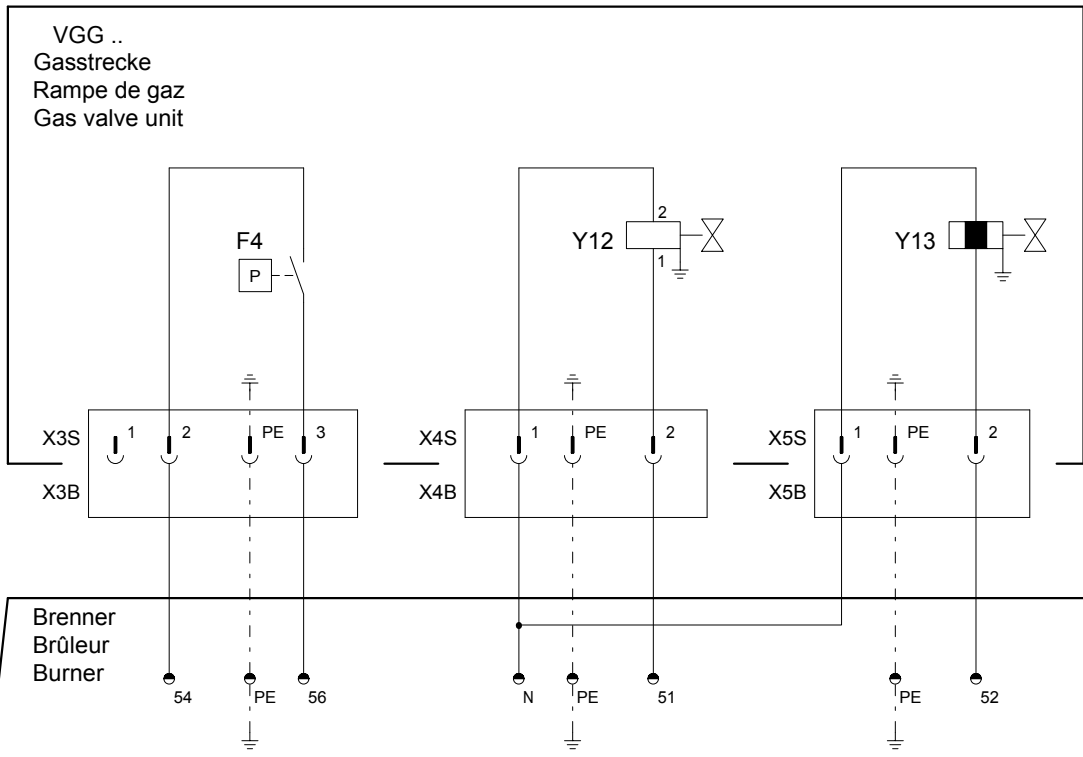
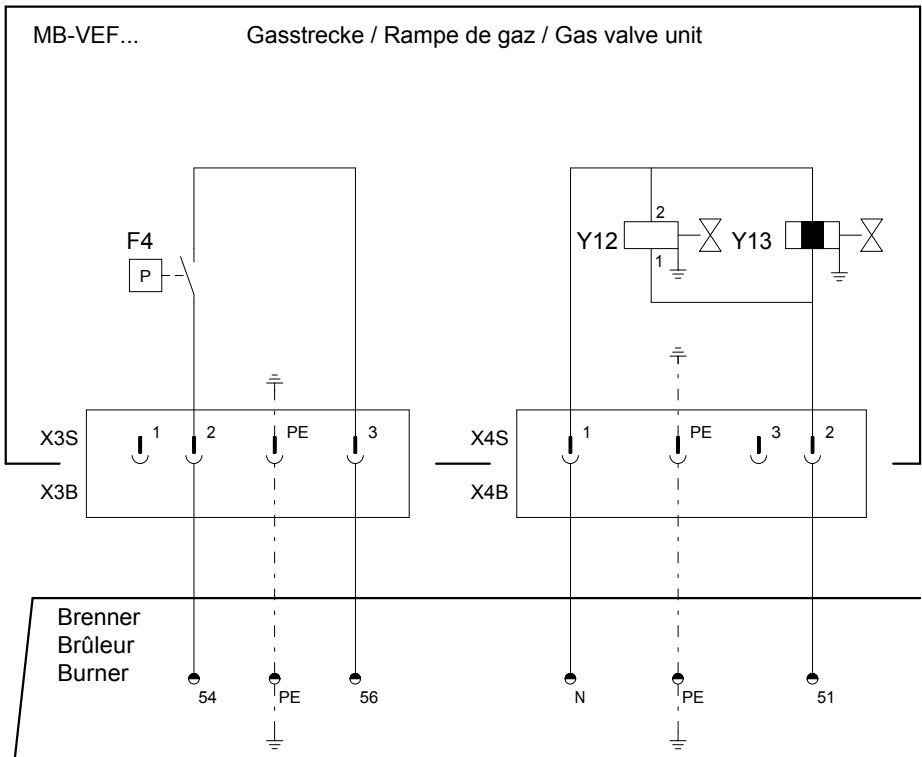

- Y12 Sicherheitshauptgasventil
Vanne gaz de sécurité
Safety gas valve
- Y13 Gasventil brennerseitig
Vanne gaz principale
Gas valve burner side
- F4 Gasdruckwacher min.
Manostat gaz min.

A
B
C
D
E
F

OPTION Störung Panne Trouble
Betriebstundenzähler Compteur horaire Running hours meter

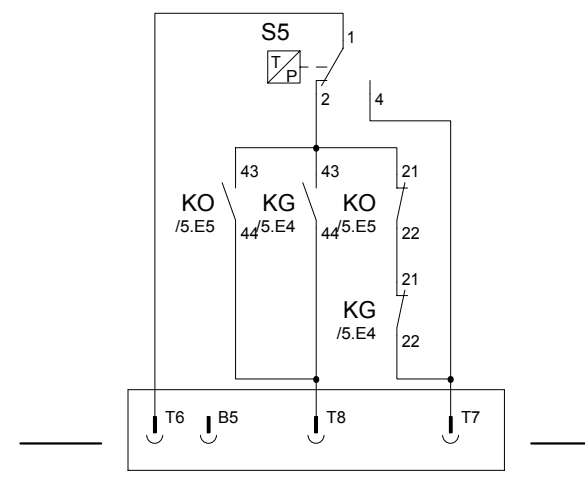
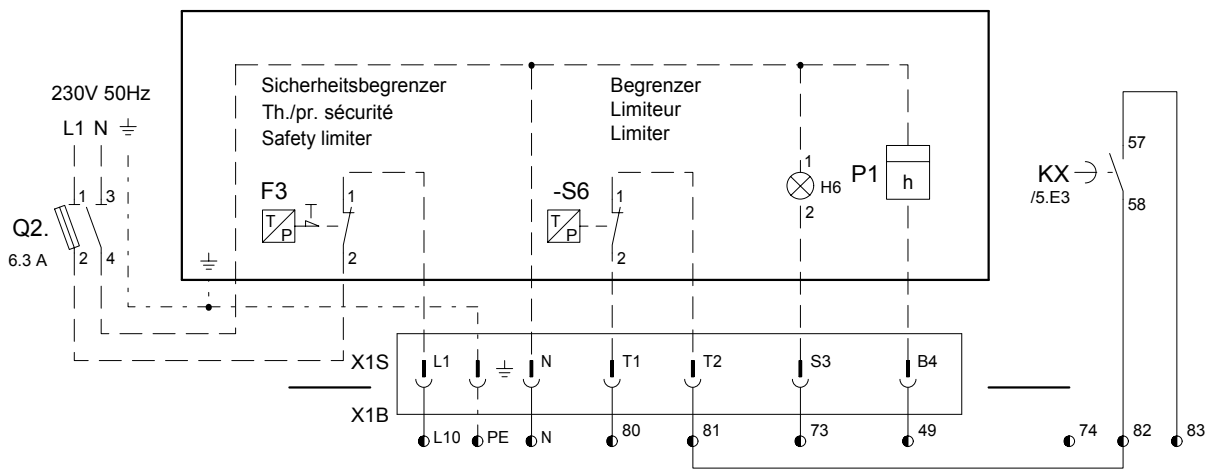

OPTION
Brennstoff Fernumschaltung

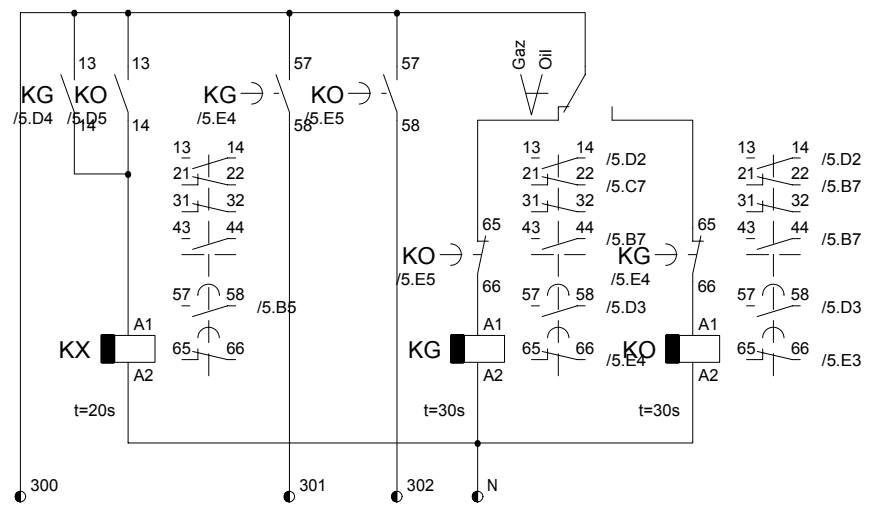

OPTION
Schutzventil
Vanne de protection
Protection valve

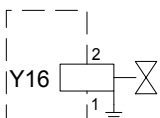

Sonde

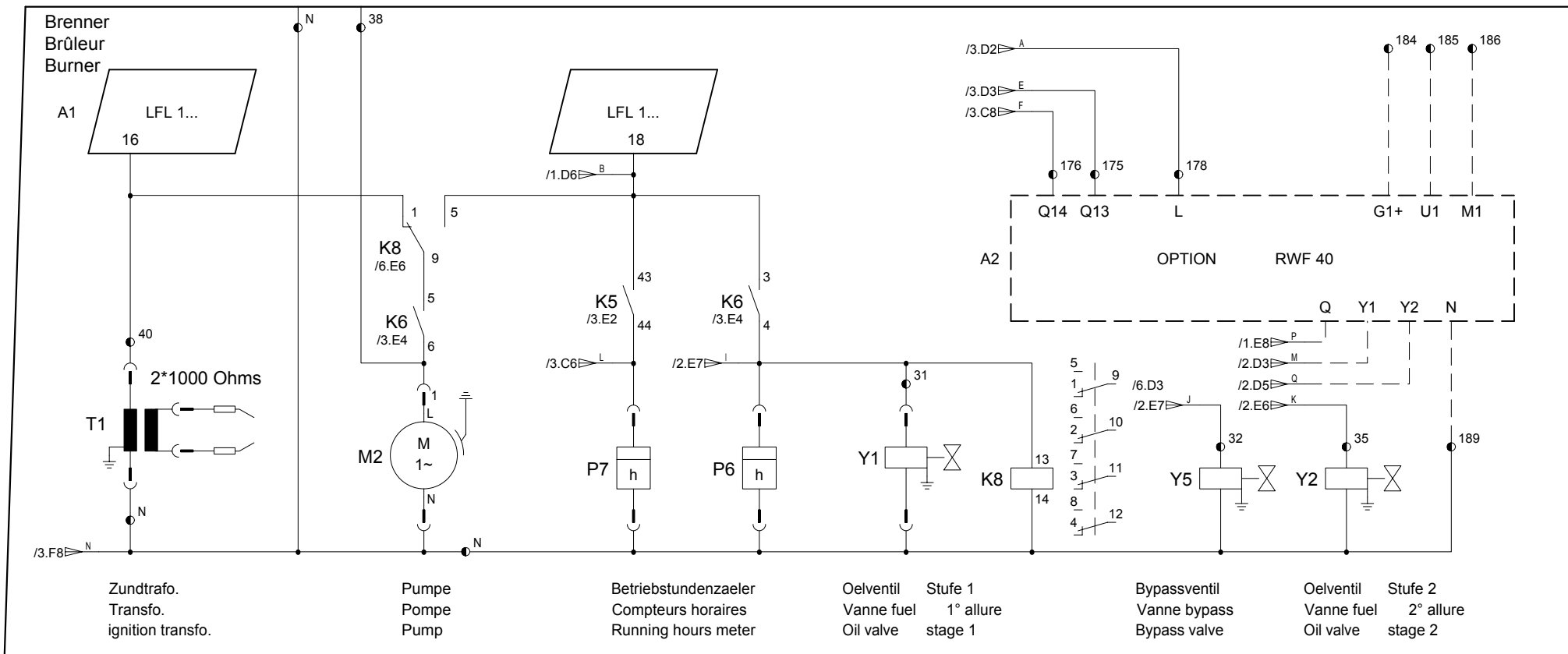

A
B
C
D
E
F

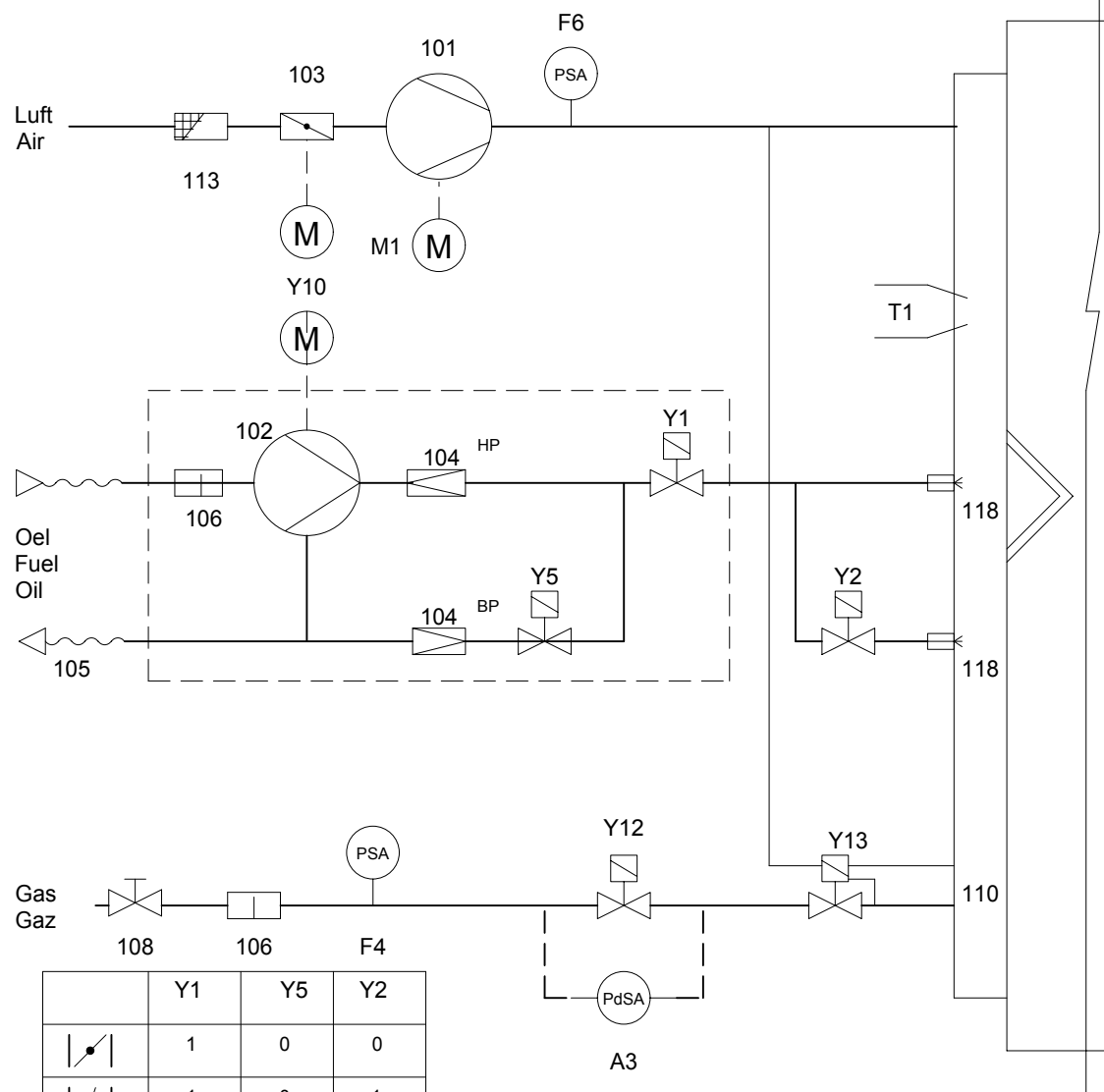

	Y1	Y5	Y2
	1	0	0
	1	0	1
	1	1	1

Oel - Fuel - Oil

A3	Dichtheitskontrolle	Controle d'étanchéité	Tightness control
F4	Gasdruckwächter min.	Manostat gaz min.	Min gas pressure
F6	Luftdruckwächter	Manostat d'air	Air pressure
M1	Brennermotor	Moteur du bruleur	Burner motor
M2	Pumpenmotor	Moteur de la pompe	Pump motor
T1	Zündtrafo.	Transfo.	Ignition transfo.
Y1	Oelventil Stufe 1	Vanne fuel 1° allure	Oil valve stage 1
Y5	Ölventil Vollast	Vanne bypass	Bypass valve
Y2	Oelventil Zwischenstufe	Vanne fuel 2° allure	Oil valve stage 2
Y10	Stellantrieb	Servomoteur	Damper motor
Y12	Sicherheitsgasventil	Vanne gaz de securite	Safety gas valve
Y13	Gasventil gasseitig	Vanne gaz principale	Gas valve burner side
101	Ventilator	Ventilateur	Impeller
102	Pumpe	Pompe	Pump
103	Luftklappe	Volet d'air	Air-damper
104	Druckregler	Régulateur de pression	Pressure regulator
105	Schlauch	Flexible	Flexible
106	Filter	Filtre	Filter
108	Handventil	Vanne manuelle	Manual valve
110	Gasinjektor	Injecteur gaz	Gas injector
113	Ansauggitter	Grille d'aspiration	Protection
118	Düsen	Gicleur	Nozzle